

# GPIO ASSIGNMENT

PIN	Define	CFG	Function
PA0	UART0_TX	5	DEBUG
PA1	UART0_RX	5	
PA2	USB0-ID	1	
PA3	LCD_SLEEP	1	SLEEP
PA4	UART1-TX	5	RS485
PA5	UART1-RX	5	
PA6	KEADC	2	
PA7	PA_SHDN	1	
PA8	RTP-XP-RST	2	RTP/CTP
PA9	RTP-YP-INT	2	
PA10	RTP-XN-SCK	2	
PA11	RTP-YN-SDA	2	

PIN	Define	CFG	Function
PB0	SPI0-HOLD	3	NAND
PB1	SPI0-WP	3	
PB2	SPI0-CS	3	
PB3	SDC0-MISO	3	SDC0
PB4	SDC0-MOSI	3	
PB5	SDC0-CLK	3	
PB6	UART4-TX	5	UART /SPI
PB7	UART4-RX	5	
PB8	UART5-TX	5	
PB9	UART5-RX	5	
PB10	UART6-TX	5	
PB11	UART6-RX	5	

PIN	Define	Define	CFG	Function	
PD0		BUZZER			
PD1		WIFI_PWR_ON			
PD2		WIFI_HOST_WAKE			
PD3		BT_PWR_ON			
PD4		BT_HOST_WAKE		I2C0	
PD5		BT_WAKE			
PD6		I2C0-SCL	4	LVDS1	
PD7		I2C0-SDA	4		
PD8		LVDS1-D0N	3		
PD9		LVDS1-D0P	3		
PD10		LVDS1-D1N	3		
PD11		LVDS1-D1P	3		
PD12		LVDS1-D2N	3		
PD13		LVDS1-D2P	3		
PD14		LVDS1-CKN	3		
PD15		LVDS1-DKP	3		
PD16		LVDS1-D3N	3		
PD17		LVDS1-D3P	3		
PD18		DSI-DN0	4		MIPI DSI
PD19		DSI-DP0	4		
PD20		DSI-DN1	4		
PD21		DSI-DP1	4		
PD22		DSI-CKN	4		
PD23		DSI-CKP	4		
PD24		DSI-DN2	4		
PD25		DSI-DP2	4		
PD26		DSI-DN3	4		
PD27		DSI-DP3	4		

PIN	Define	CFG	Function
PE0	MAC0-RXD1	6	MAC0 100M
PE1	MAC0-RXD0	6	
PE2	MAC0-CRS-DV	6	
PE3	MAC0-REFCLK	6	
PE4	MAC0-TXD1	6	
PE5	MAC0-TXD0	6	
PE6	ETH0_RST	1	
PE7	MAC0-TXEN	6	
PE8	MAC0-MDC	6	
PE9	MAC0-MDIO	6	
PE10	EPHY0-25M	6	SPEAKER
PE11	SPK1	4	
PE12	DMIC_CLK	4	DMIC
PE13	DMIC_DATA	4	
PE14	UART3-TX	5	RS485
PE15	UART3-RX	5	
PE16	CAN0-TX	4	CAN0
PE17	CAN0-RX	4	
PE18	CAN1-TX	4	CAN1
PE19	CAN1-RX	4	

PIN	Define	CFG	Function
PU0	USB0-DM	2	USB0
PU1	USB0-DP	2	
PU2	USB1-DM	2	USB1
PU3	USB1-DP	2	

PIN	Define	CFG	Function
PF0	SDC2-D1		WIFI
PF1	SDC2-D0		
PF2	SDC2-CLK		
PF3	SDC2-CMD		
PF4	SDC2-D3		
PF5	SDC2-D2		BT
PF6	UART7-TX		
PF7	UART7-RX		
PF8	UART7-RTS		I2S/PCM
PF9	UART7-CTS		
PF10	I2S1-MCLK		
PF11	I2S1-BCLK		
PF12	I2S1-LRCK		
PF13	I2S1-DOUT		
PF14	I2S1-DIN		
PF15	KEY_WAKEUP		WAKEUP

PIN	Define	CFG	Function
PC0	SDC1-D1	2	CARD
PC1	SDC1-D0	2	
PC2	SDC1-CLK	2	
PC3	SDC1-CMD	2	
PC4	SDC1-D3	2	
PC5	SDC1-D2	2	
PC6	SDC1-DET	2	
PC7	LCD_PWM	1	Backlight

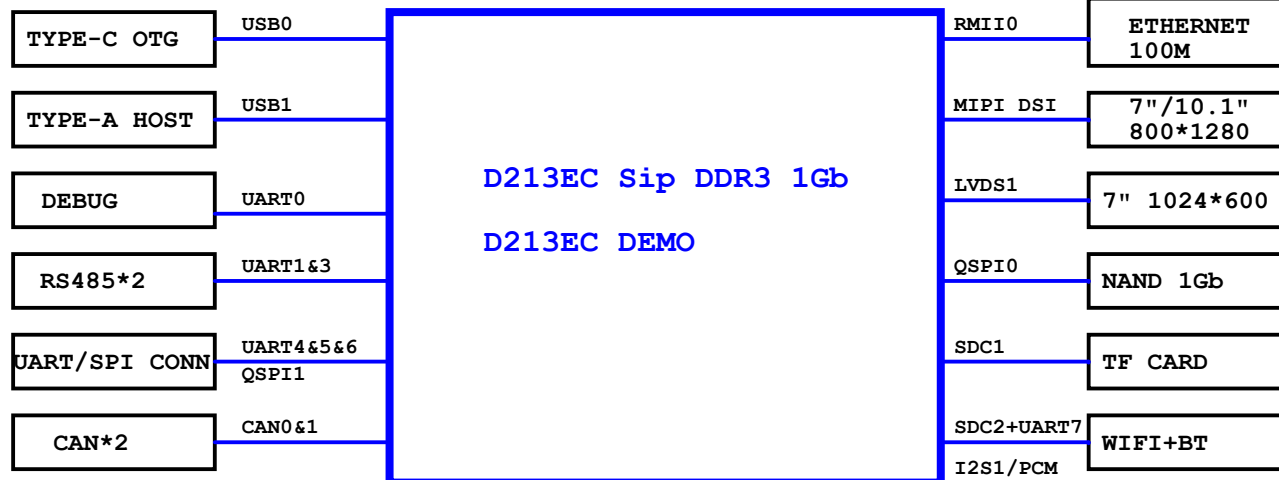

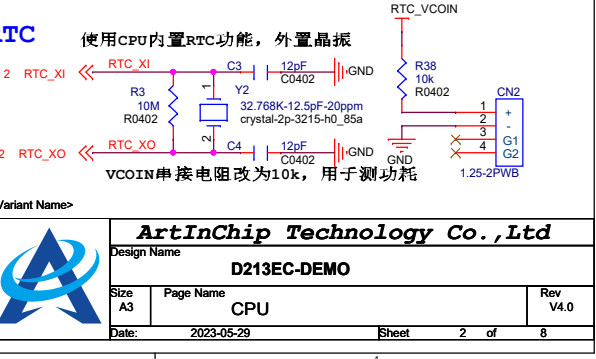
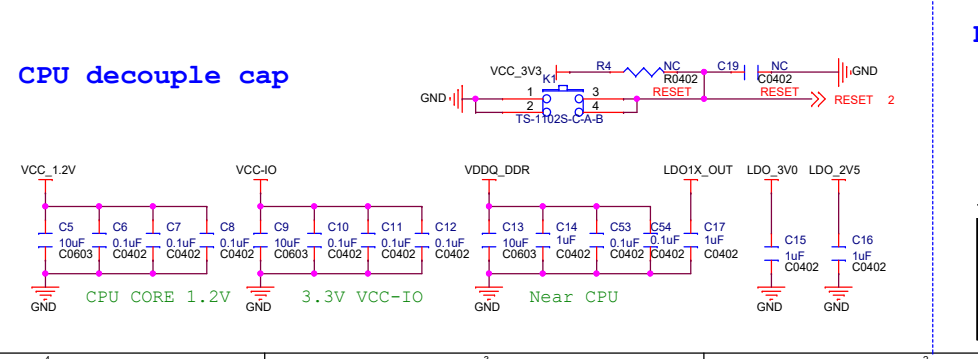
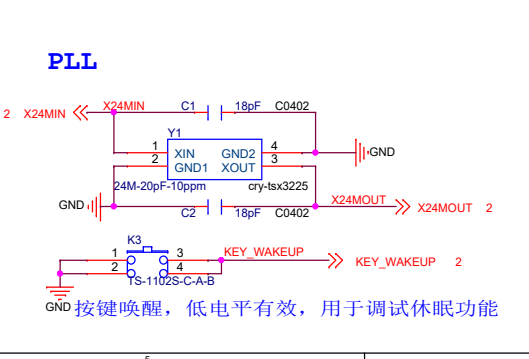
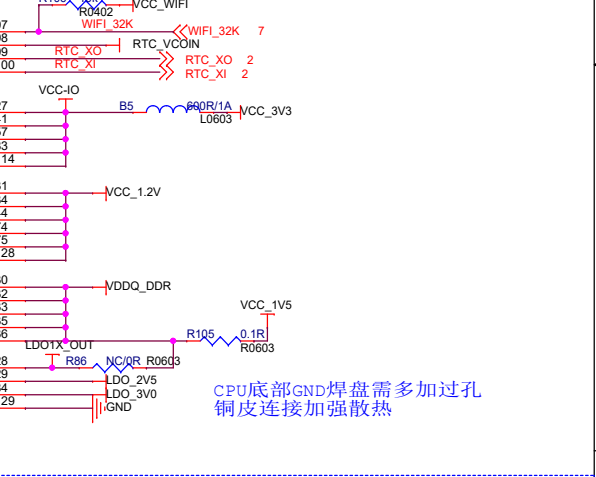
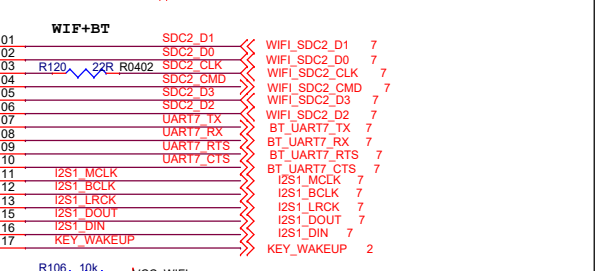
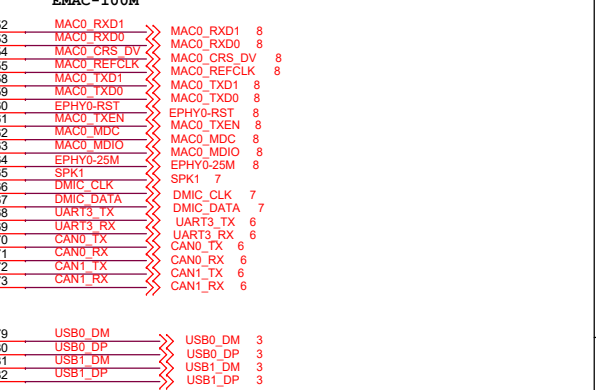
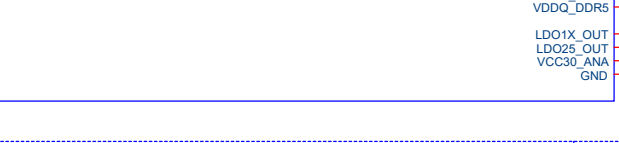
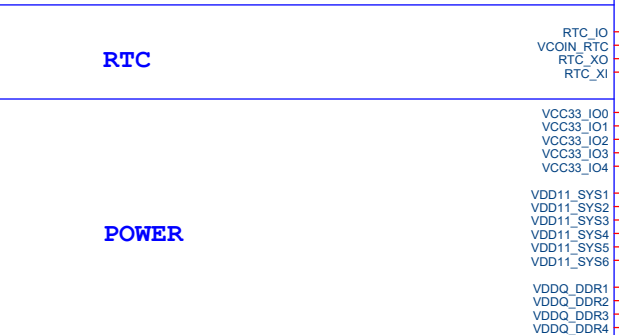
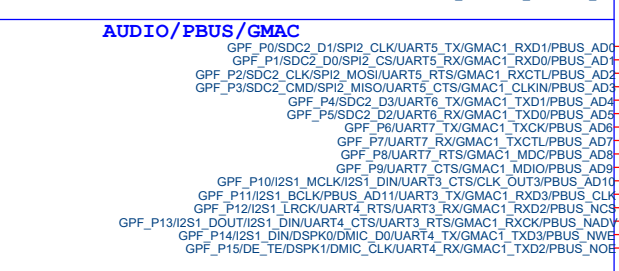
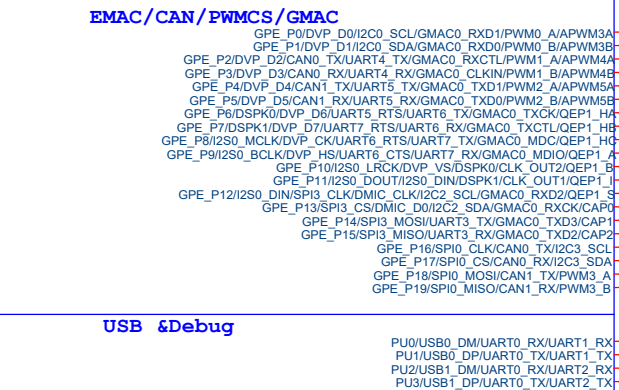
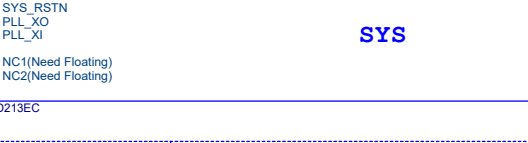
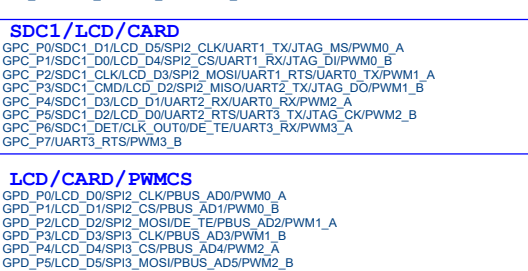
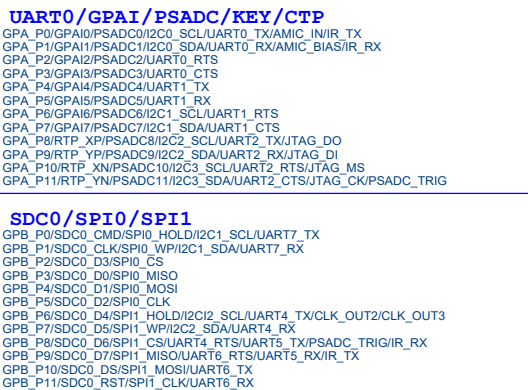
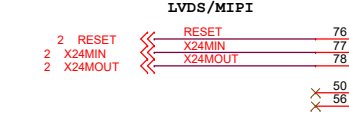
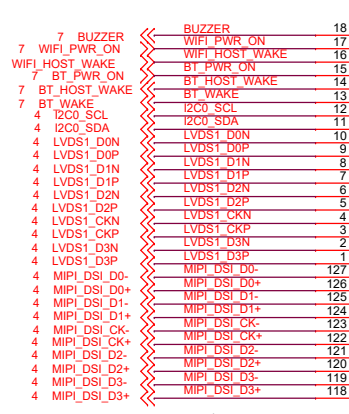
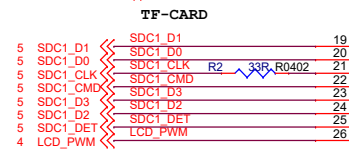
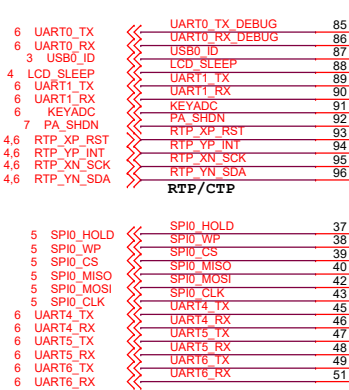

ArtInChip Technology Co., Ltd

Design Name: D213EC-DEMO

Size: A3 Page Name: CPU Rev: V4.0

Date: 2023-05-29 Sheet: 2 of 8

### USB0 DEVICE or HOST SWITCH

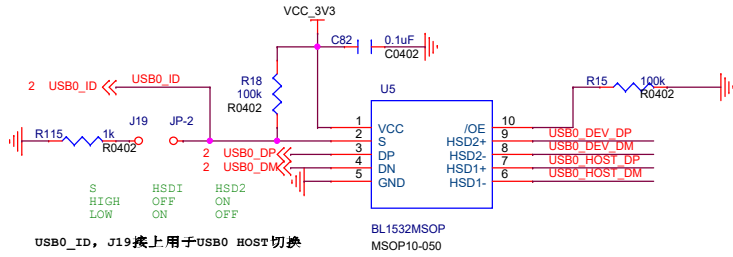

### USB0 HOST

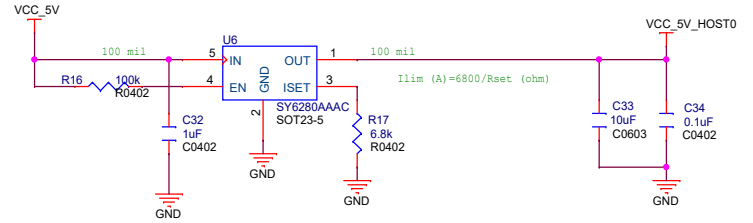

注释1: Ilim(A)=6800/Rset, VBUS按至少1A走线

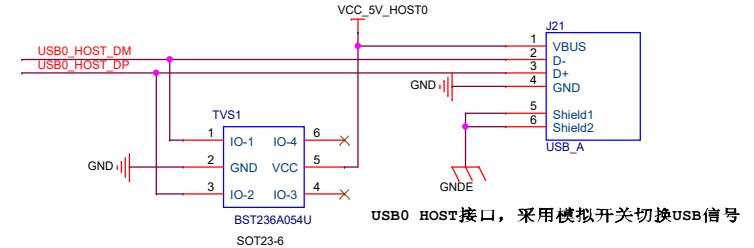
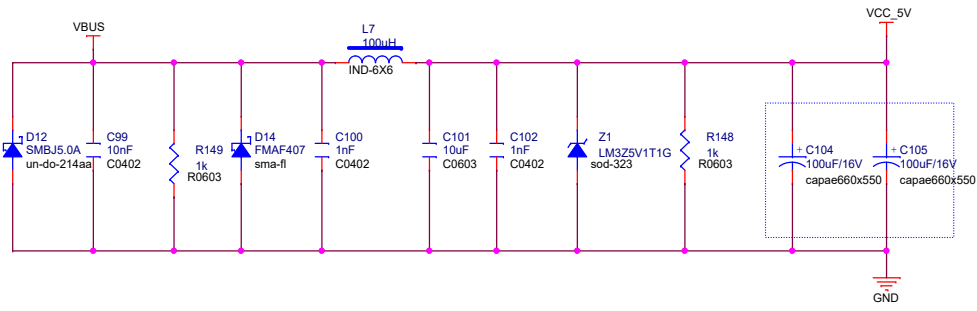

USB0 HOST接口, 采用模拟开关切换USB信号

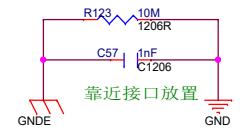

靠近接口放置

### USB0 DEVICE

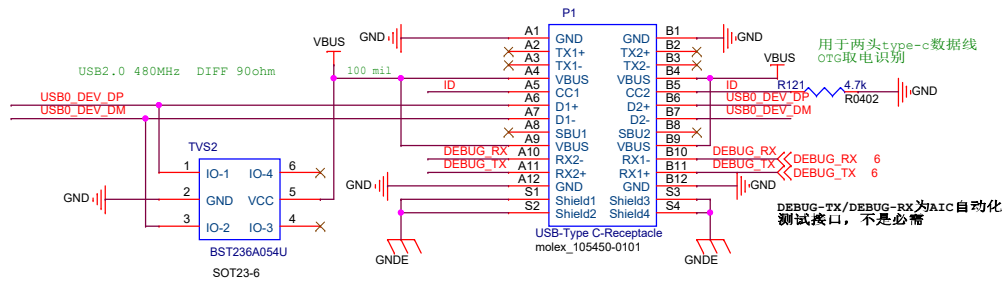

### USB1 HOST

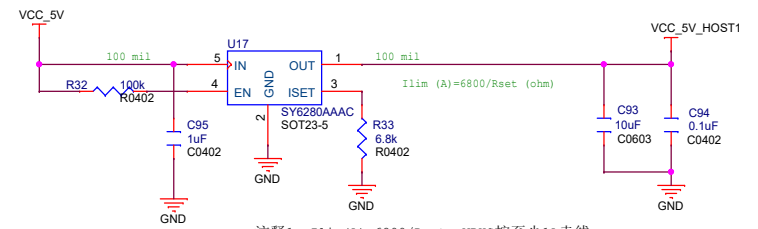

注释1: Ilim(A)=6800/Rset, VBUS按至少1A走线

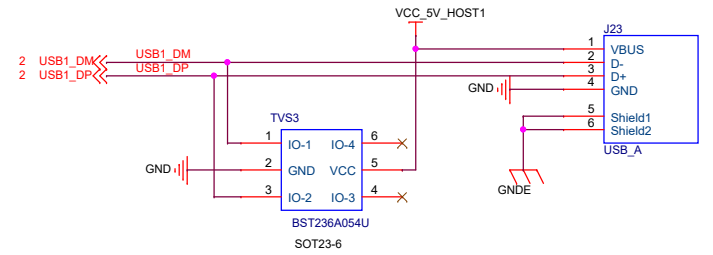

<Variant Name>

<b>ArtInChip Technology Co., Ltd</b>		
Design Name		<b>D213EC-DEMO</b>
Size	Page Name	Rev
A3	USB	V4.0
Date:	2023-05-29	Sheet 3 of 8

# LVDS (Option)

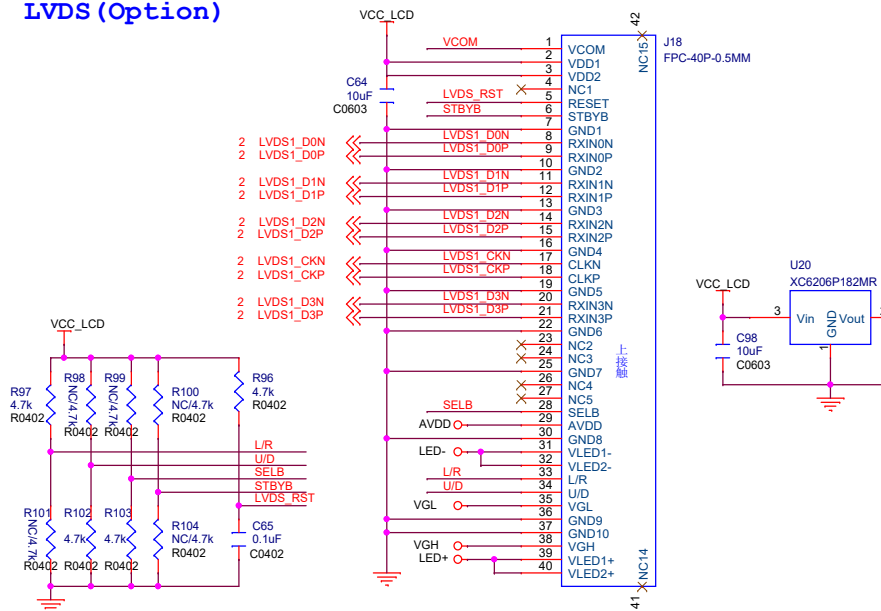

# MIPI

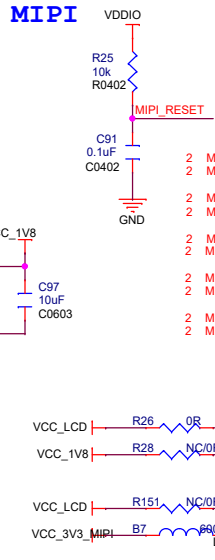

# 10.1" 40Pin

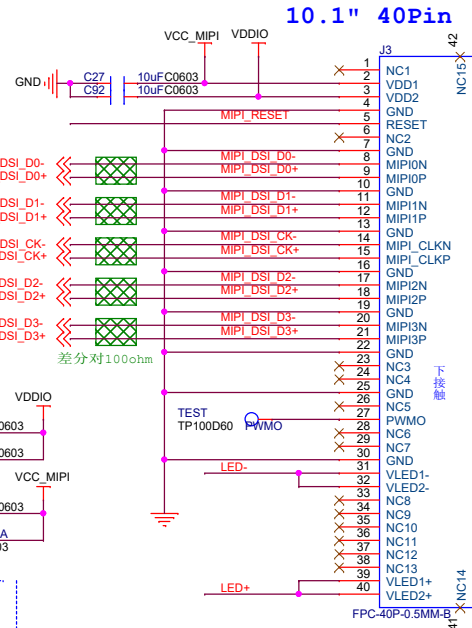

# 7"/10.1" 31Pin

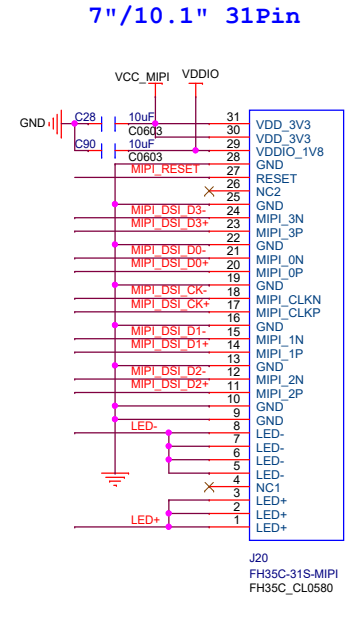

# LCD POWER

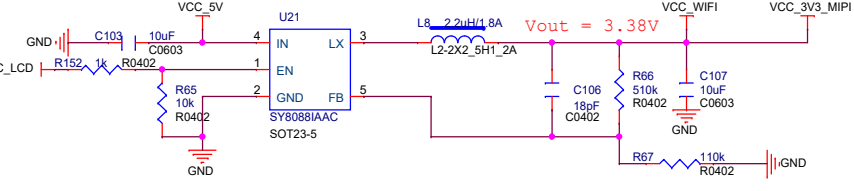
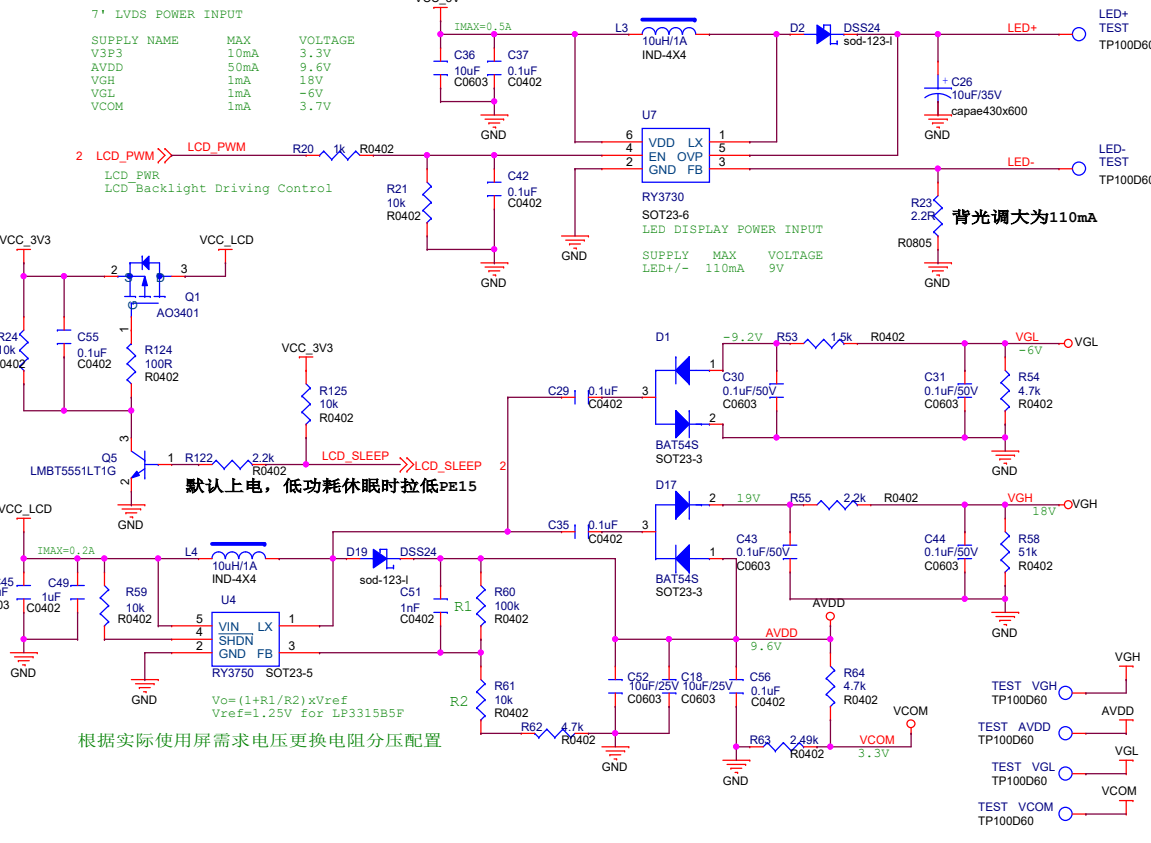

# RTP

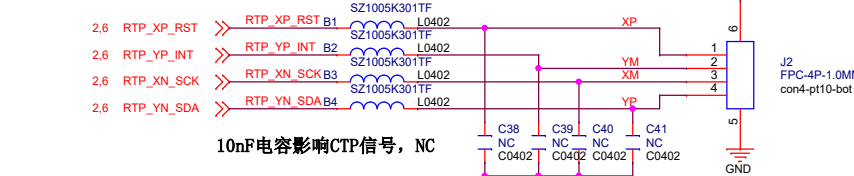

# CTP

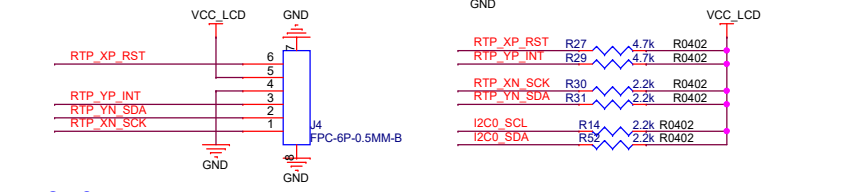

# I2C0

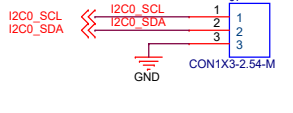

ArtInChip Technology Co., Ltd

Design Name: D213EC-DEMO

Size: A3, Page Name: LCD/TP, Rev: V4.0

Date: 2023-05-29, Sheet: 4 of 8

### SPI NAND

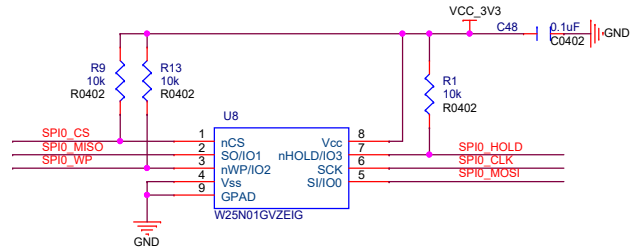

### 1.2V

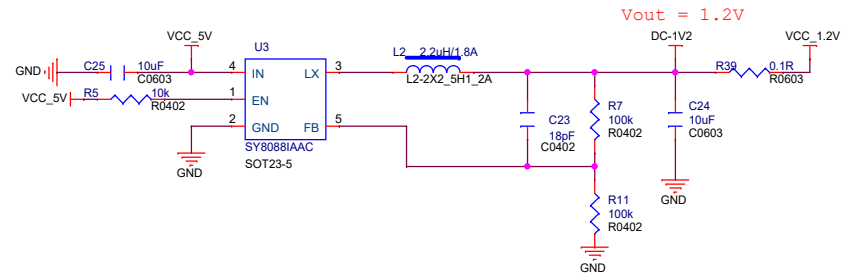

### 3.3V

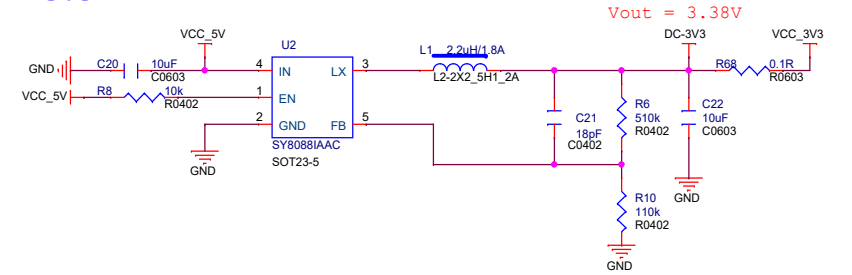

### TF-CARD

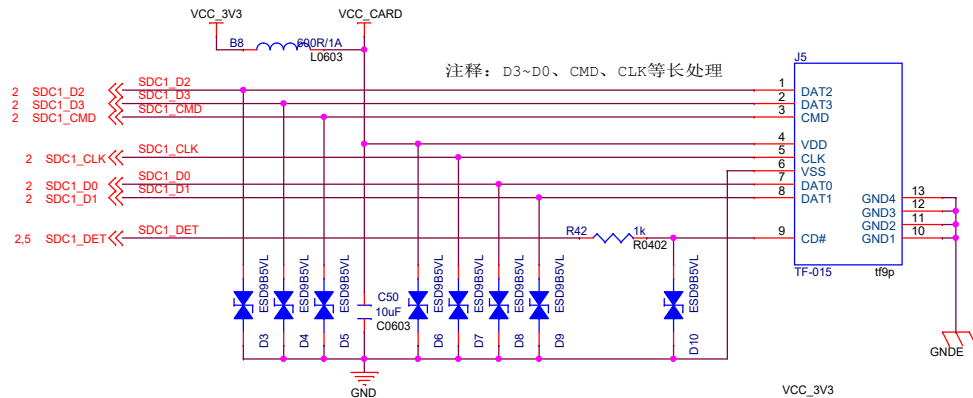

注释: D3~D0、CMD、CLK等长处理

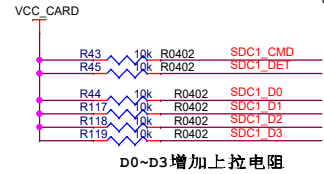

D0~D3增加上拉电阻

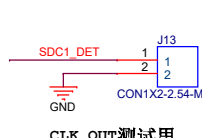

CLK\_OUT测试用

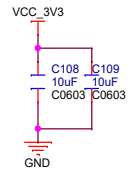

状态指示灯

### 1.5V for DRAM

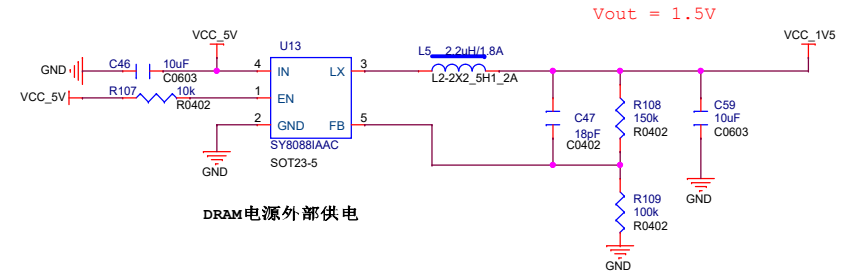

DRAM电源外部供电

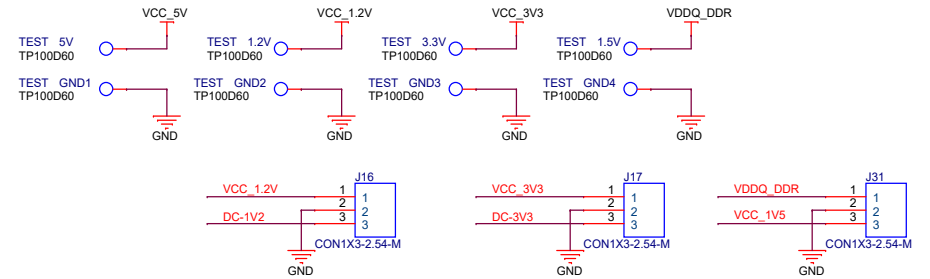

测试整机分量电流

测试整机分量电流

测试整机分量电流

<Variant Name>

<b>ArtInChip Technology Co., Ltd</b>		
Design Name	<b>D213EC-DEMO</b>	
Size A3	Page Name	Rev V4.0
	<b>POWER/NAND/CARD</b>	
Date: 2023-05-29	Sheet 5 of 8	

# RS485

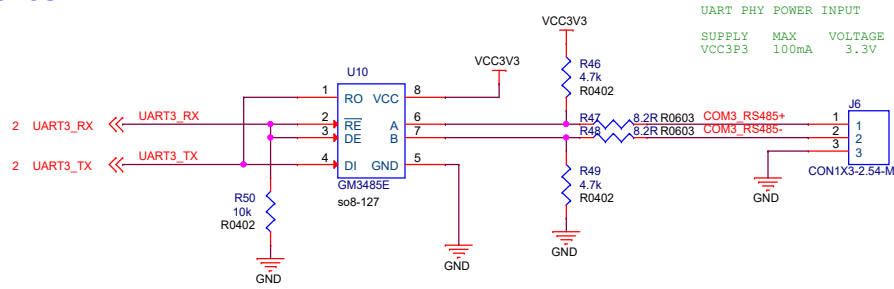

RS485 两线制模式接法, 可节省1个PIN, 自动控制收发

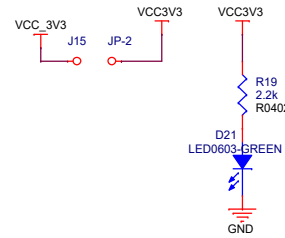
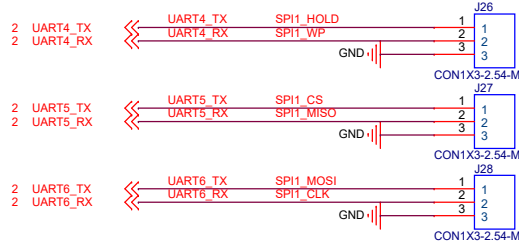
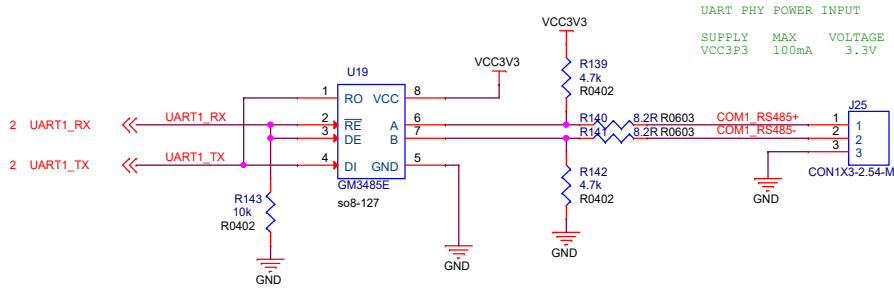

# JTAG (Option)



# DEBUG-UART0

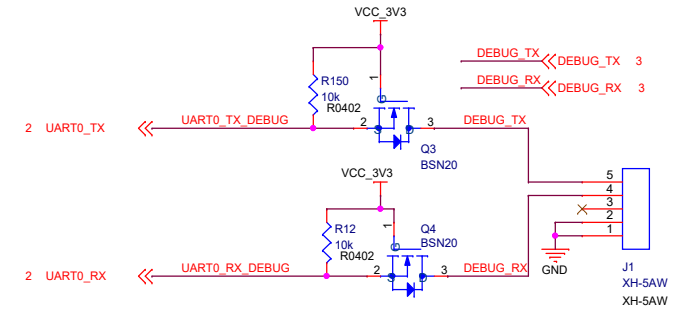

# UBOOT-KEY

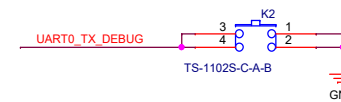

# CAN0&1

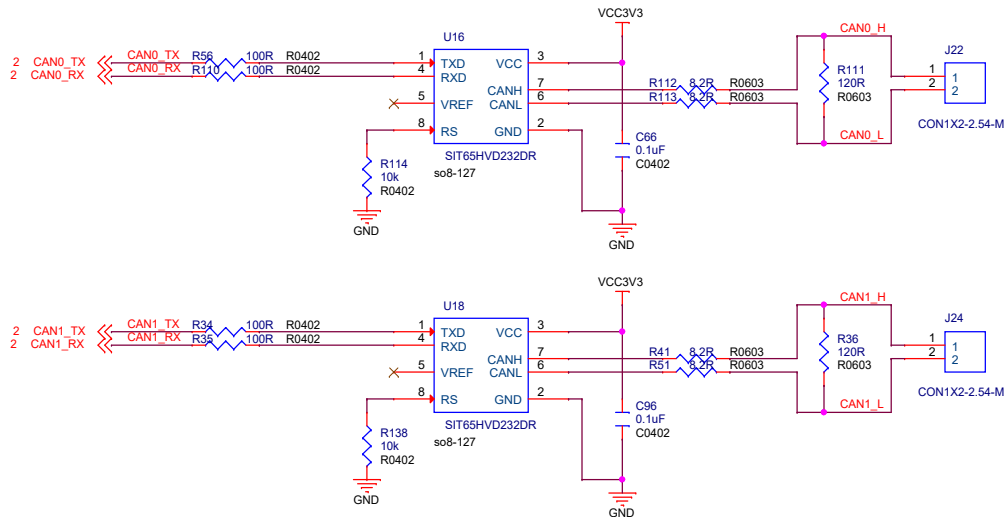

# KEYADC

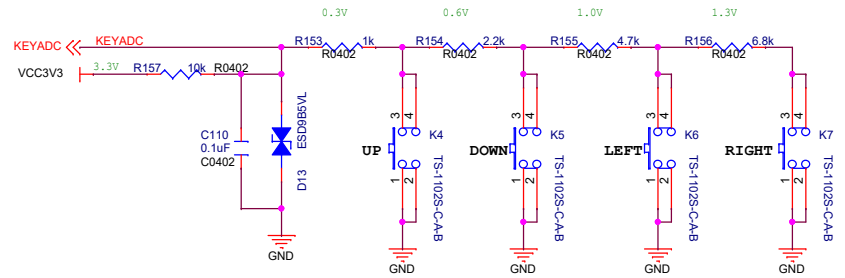

# WIFI+BT

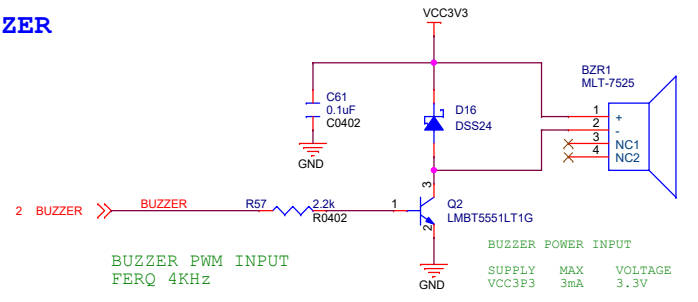
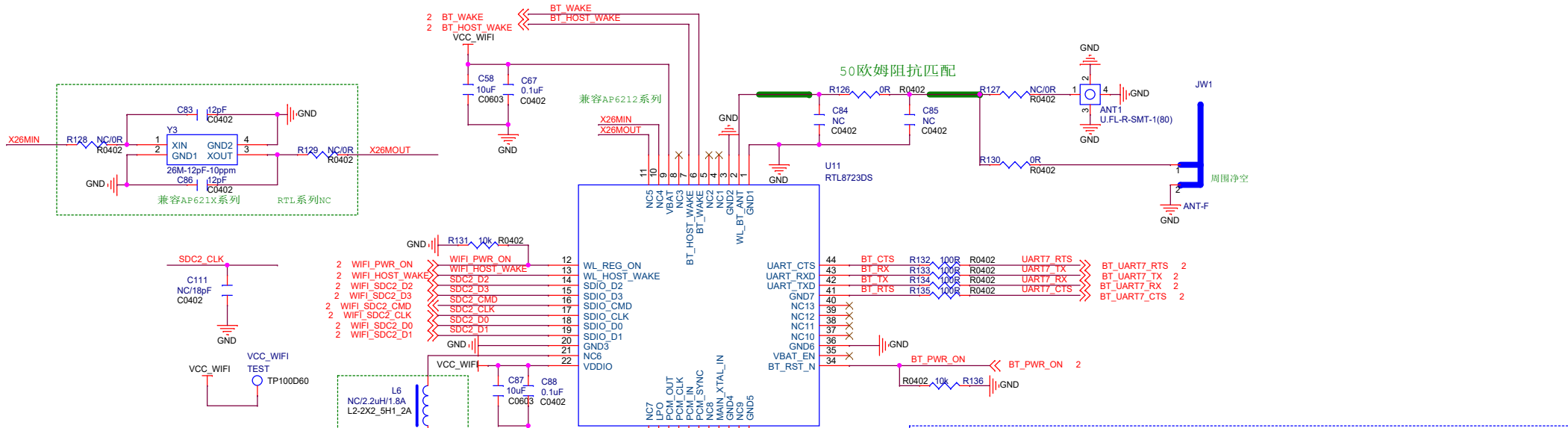

# SPEAKER

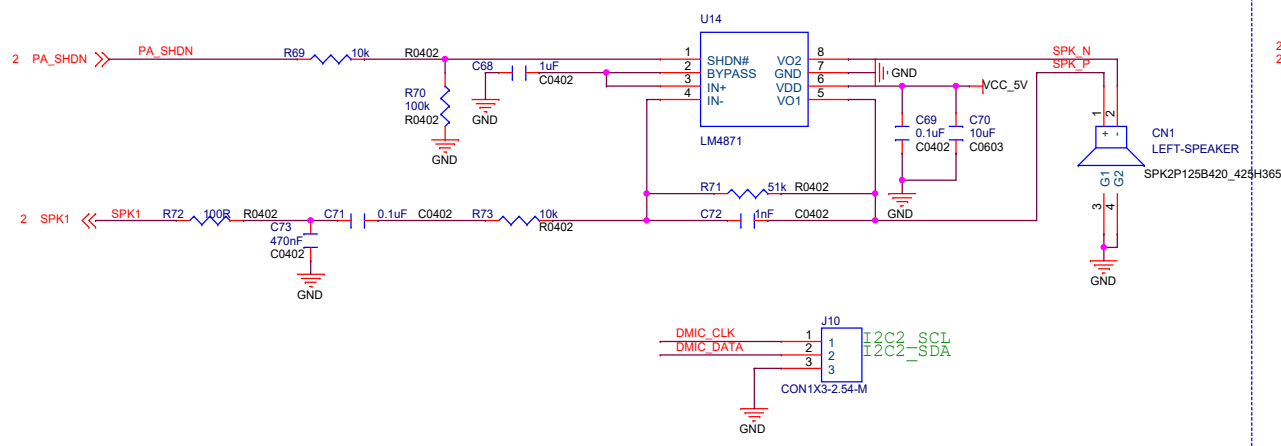

# DMIC

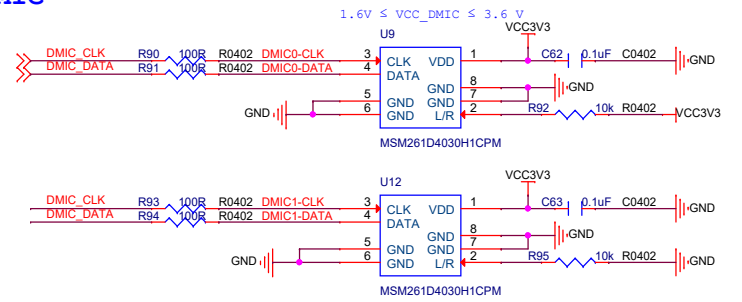

注释：单声道只选择一路L或R；立体声选择两路，L/R分别上拉、下拉

<Variant Name>

**ArtInChip Technology Co., Ltd**

Design Name: **D213EC-DEMO**

Size: A3 Page Name: **SPEAKER** Rev: V4.0

Date: 2023-05-29 Sheet: 7 of 8

# RMII0-100M

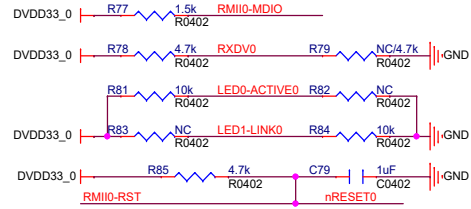
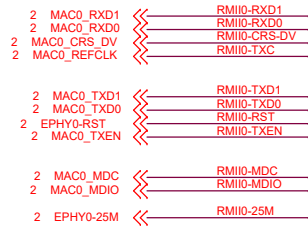

	Pull high	Pull down
RXDV	RMII mode	MII mode
RXD3(内部PD)	TXC input	TXC output
RXD1(内部PD)	WOL mode	LED mode

PHY-ADDR	LED1-LINK	LED0-ACTIVE
addr = 5' d0	Pull down	Pull down
addr = 5' d1	Pull down	Pull high
addr = 5' d2	Pull high	Pull down
addr = 5' d3	Pull high	Pull high

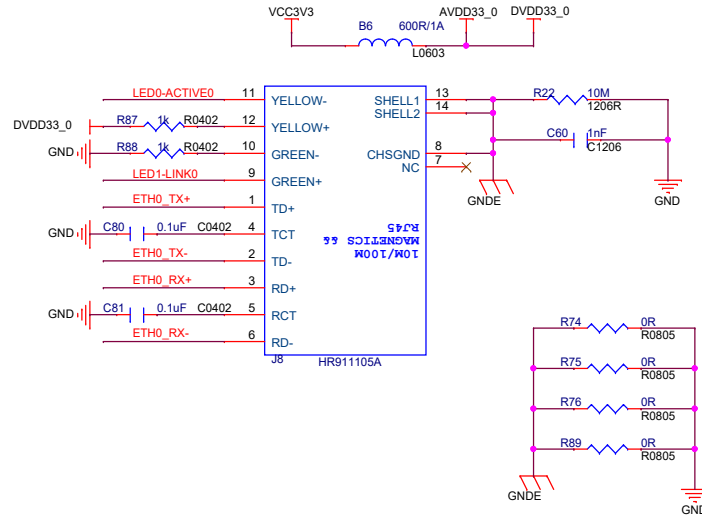
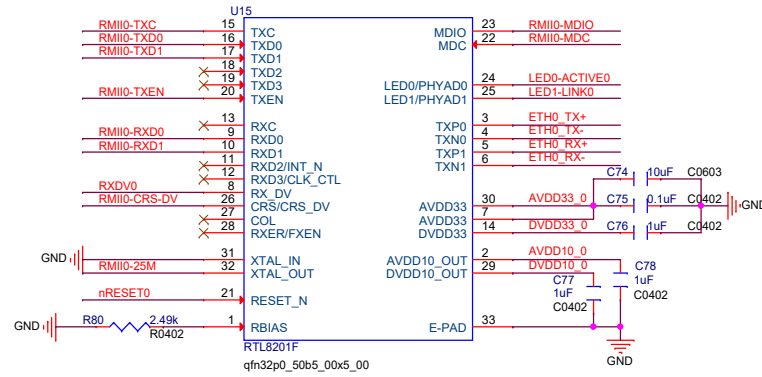

<Variant Name>

<b>ArtInChip Technology Co., Ltd</b>		
Design Name	D213EC-DEMO	
Size A3	Page Name	Rev V4.0
Date: 2023-05-29	Sheet 8 of 8	